

Chipping Hammers

The BEST Chipping Hammer Value in the Industry



- * **4 Bolt design for longer life of handle.**
- * **Quick Change Retainer for ease in changing tools.**
- * **Hose swivel so hose tracks operator movement.**
- * **Lubricator to enhance tool life.**
- * **Rugged construction for use in Shipyards, Refineries and Oil Field Equipment Manufacturers.**

2

PRICES INCLUDE TX-4HW HOSEWHIP ASSEMBLY AND A 1291-TPT2 DELUXE QUICK CHANGE RETAINER.

* See page 65 for available chisels & points

SPECIFICATIONS:							
MODEL #	BORE	PISTON STROKE	NUMBER OF IMPACTS PER MINUTE	HOSE SIZE	OVERALL LENGTH	AIR CONSUMPTION	WEIGHT
TX-CH2-4B	1-1/8	2"	2100	1/2"	14-1/2"	32-34 CFM	18#
TX-CH3-4B	1-1/8	3"	1650	1/2"	15-1/2"	33-35 CFM	19#
TX-CH4-4B	1-1/8	4"	1375	1/2"	16-1/2"	34-36 CFM	20#

Texas Pneumatic is proud to offer a chipping hammer completely made in the USA. We will guarantee the quality of this chipping hammer versus any chipping hammer in the world.

Quality Tools & Parts • Value Pricing • Fastest Response Time

4 - Bolt Chipping Hammer

TXCH-4B

2

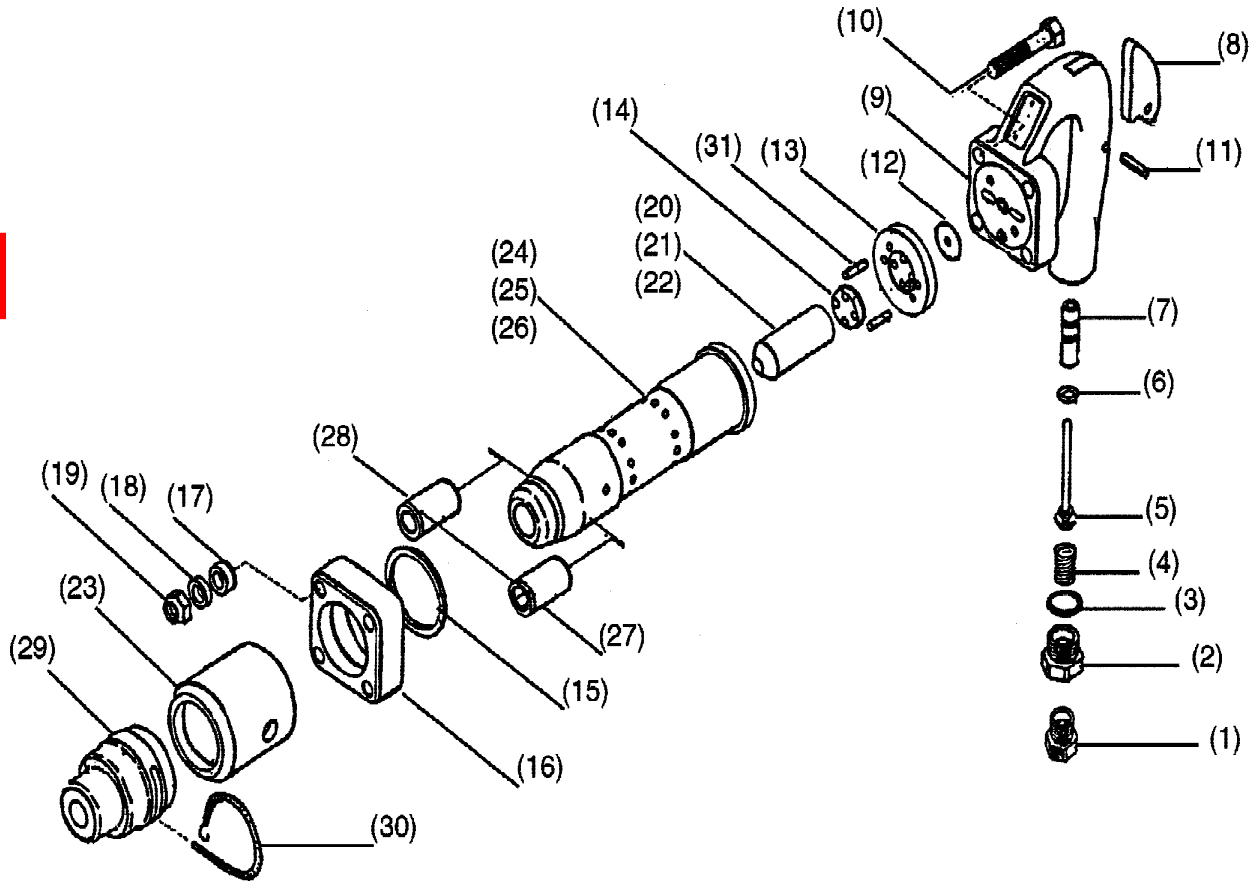

Part List

INDEX NO.	PART NO.	DESCRIPTION	INDEX NO.	PART NO.	DESCRIPTION
1	TX-01008	7/8-24 PERMANENT BUSHING	18	TX-4B496	STEEL HANDLE BOLT SPACER
2	TX-4B504	7/8-24 I.D X 1-1/16 12 O.D INLET BUSHING	19	TX-4B497	NYLON HANDLE BOLT NUT
3	TX-4B490	"O" RING	20	TX-4B500	2" PISTON
4	TX-4B489	THROTTLE VALVE SPRING	21	TX-4B501	3" PISTON
5	TX-4B488	THROTTLE VALVE	22	TX-4B505	4" PISTON
6	TX-4B431	"O" RING	23	TX-4B499	EXHAUST DEFLECTOR
7	TX-4B487	T.V. STEM BUSHING	24	TX-4B498	2" STROKE BARREL
8	TX-4B486	TRIGGER	25	TX-4B502	3" STROKE BARREL
9	TX-4B484	HANDLE, BARE	26	TX-4B503	4" STROKE BARREL
10	TX-4B485	HANDLE BOLT (4 PER TOOL)	27	TX-01031	HEX FRONT END BUSHING
11	TX-4BPIN	THROTTLE LEVER PIN	28	TX-01030	ROUND FRONT END BUSHING*
12	TX-4B483	AUTOMATIC VALVE	29	1190-TPT1	RETAINER
13	TX-4B482	VALVE SEAT	NS	1291-TPT2	(SEE NEXT PAGE)
14	TX-4B480	VALVE SEAT BUMPER	30	1194-2	RETAINER LOCK SPRING
15	TX-4B493	ABSORBER RING	31	TX-4B481	VALVE LOCATOR PIN
16	TX-4B494	BARREL FLANGE	NS	TX-4HW	HOSE WHIP ASSEMBLY
17	TX-4B495	VIBRATION SPACER			

* TOOL COMES STANDARD WITH ROUND FRONT END BUSHING

4 - Bolt Chipping Hammer

Deluxe Quick Change Retainer 1291

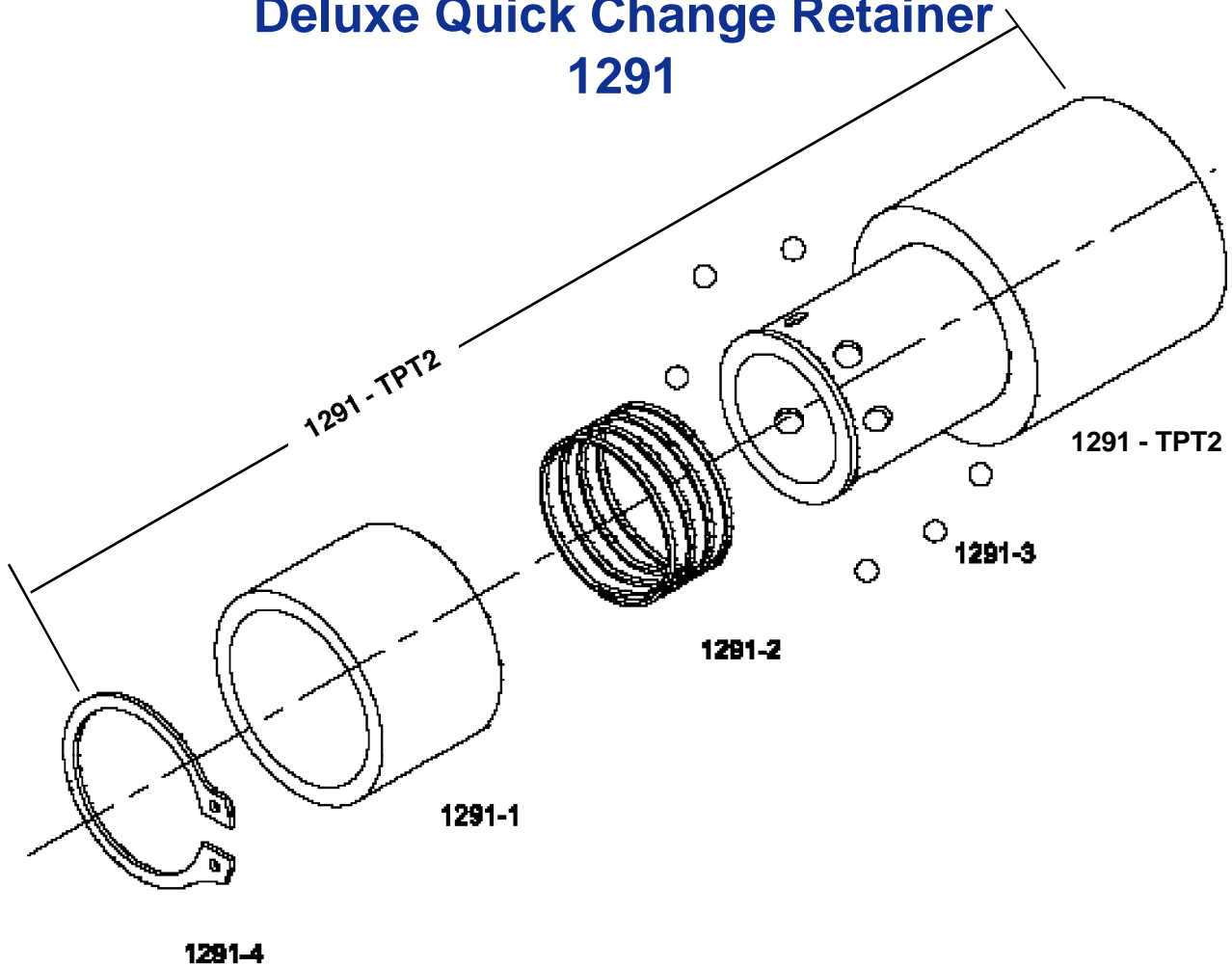

Part List

Index No.	Part No.	Description
1	1291	BODY
2	1291-3	SET OF 6 BALLS
3	1291-2	SPRING
4	1291-1	SLEEVE
5	1291-4	RETAINER CLIP