



Repair And Maintenance Manual

For

“PROMAXX™” Paving Breaker

Models: MX60/60S & MX90/90S



Read this instruction manual before operating this equipment.

Designed and Built by Ingersoll-Rand Company
Roanoke, Va. 24019-5198 U.S.A.



Certified ISO-9001 (ANSI/ASQC Q91)
Certification No. QSR-80

CPN : 51984144
December, 2001

RM6085
Revision 4

TABLE OF CONTENTS

| | |
|--------------------------------------|------------------|
| INTRODUCTION | SECTION 1 |
| Introduction | |
| Reference Manual | |
| SAFETY | SECTION 2 |
| Introduction | |
| Safety Alert Symbol and Signal Words | |
| Safety First | |
| MAINTENANCE | SECTION 3 |
| Introduction | |
| Maintenance | |
| Disassembly | |
| Inspection & Repair | |
| Reassembly | |
| Performance Testing | |
| TROUBLESHOOTING | SECTION 4 |
| Introduction | |
| Troubleshooting | |
| MAINTENANCE RECORDS | SECTION 5 |

Alphabetical Index

| Title | Page No. |
|--------------------------|----------|
| INTRODUCTION | 1 |
| REFERENCE MATERIAL | 1 |

1. INTRODUCTION.

This maintenance and repair manual contains information for maintenance, service and troubleshooting for the "PROMAXX™" Paving Breaker Models MX60/60S & MX90/90S.

2. REFERENCE MATERIAL.

The reference material required to operate and/or maintain the paving breakers are listed in Table 1.

Table 1. Reference Material

| Manual No. | Title Of Manual |
|------------|--|
| PL6085 | Parts Lists for "PROMAXX™" Paving Breaker Models MX60/60S & MX90/90S. |
| IM6085 | Instruction Manual for "PROMAXX™" Paving Breaker Models MX60/60S & MX90/90S. |

NOTICE

SAVE THESE INSTRUCTIONS. DO NOT DESTROY.

All information, illustrations, and specifications in this parts list are based on the latest information available at the time of publication.

Product improvement is a continuing goal at Ingersoll-Rand™. Design and specifications are subject to change without notice or obligation.

The use of repair parts other than those included within the Ingersoll-Rand® approved parts list may create hazardous conditions over which Ingersoll-Rand® Company has no control. Therefore Ingersoll-Rand® Company cannot be held responsible for equipment in which non-approved repair parts are installed.

When the life of the tool has expired, it is recommended that the tool be disassembled, degreased and parts be separated by material so that they can be recycled.

Alphabetical Index

| Title | Page No. |
|--|----------|
| INTRODUCTION | 1 |
| SAFETY ALERT SYMBOL AND SIGNAL WORDS | 1 |
| SAFETY FIRST | 1 |

1. INTRODUCTION.

This section contains important safety information for "PROMAXX •" Paving Breaker Models MX60/60S & MX90/90S.

2. SAFETY FIRST.

SAFETY FIRST is the primary concern for the protection of both, personnel and the paving breaker during any phase of operation. All personnel must thoroughly understand all safety precautions before operating or doing any maintenance work on the paving breaker.

3. SAFETY ALERT SYMBOL AND SIGNAL WORDS.

 – This is the Safety Alert Symbol. When you see this symbol in this maintenance manual, be alert to the presence of a hazard.

All personnel must understand the **DANGER**, **WARNING**, **CAUTION**, and **NOTICE** used throughout the text of this instruction manual. The **DANGER**, **WARNING**, **CAUTION**, and **NOTICE** are defined as follows:



DANGER IS USED TO INDICATE THE PRESENCE OF A HAZARD WHICH WILL CAUSE SEVERE INJURY OR DEATH IF THE WARNING IS IGNORED.



WARNING IS USED TO INDICATE THE PRESENCE OF A HAZARD WHICH CAN CAUSE SEVERE INJURY OR DEATH IF THE WARNING IS IGNORED.



CAUTION IS USED TO INDICATE THE PRESENCE OF A HAZARD WHICH WILL OR CAN CAUSE INJURY, OR PROPERTY DAMAGE IF THE WARNING IS IGNORED.



Notice is used to notify people of installation, operation, or maintenance information which is important but not hazard related.

By understanding what **DANGER**, **WARNING**, **CAUTION**, and **NOTICE** mean; and using good judgment and common sense; all personnel can avoid injuring themselves and/or damaging the paving breaker.

Alphabetical Index

| Title | Page No. |
|-----------------------|----------|
| INTRODUCTION | 1 |
| MAINTENANCE | 1 |
| DISASSEMBLY | 1 |
| INSPECTION AND REPAIR | 4 |
| REASSEMBLY | 4 |
| PERFORMANCE TESTING | 5 |

1. INTRODUCTION.

This section provides information on maintenance and performance testing of the "PROMAXX"™ Paving Breaker Models MX60/60S & MX90/90S.

2. MAINTENANCE.

To ensure maximum life and top performance of the equipment, it is necessary that the maintenance be made before serious damage occurs. It is important to be cautious when performing any service work. A general knowledge of the system and/or components is important before the removal or disassembly of any components. The following is a list of basic precautions that must always be observed:

- a. Never attempt major maintenance of the paving breaker on the job; always send the paving breaker to a repair shop.
- b. Clean the exterior of the paving breaker before disassembly.
- c. Provide a clean work area for disassembling the paving breaker.
- d. Handle parts carefully. Hardened parts might chip or break if dropped on a hard surface.
- e. Place small parts in a clean box to prevent loss.
- f. Keep your hands and the paving breaker clean and free of dirt, while assembling.
- g. Wipe a film of clean oil over the working parts as they are assembled.
- h. Do not allow dirt or chips from soft drifts and hammers to enter the paving breaker.
- i. With the exception of pressed-in parts, all the parts should fit together easily. If excessive force is required, the part is probably cocked and should be removed and realigned.
- j. If necessary, use a rubber mallet to loosen the fronthead and backhead.

3. DISASSEMBLY. (Figure 1)

- a. Set the breaker vertically on the floor.
- b. If equipped with a muffler, remove bolt (210) and washer (400). Slide the muffler off of the housing (1).
- c. Remove the backhead bolts (205) and the backhead washers (400) from the housing (1). Lift the backhead (3) off the housing.
- d. If damaged, remove the oil fill plug (21) from the backhead (3), and the oil fill plug o-ring (300).
- e. Remove the throttle lever (10) from the housing plug (6).
- f. Remove the backhead o-ring (305) from the housing plug (6).
- g. Using a pair of adjustable pliers, pull the housing plug (6) out of the housing bore.
- h. Remove the housing plug o-rings (315) from the housing plug.
- i. If damaged or dirty, remove the filter (20) from the housing plug (6).
- j. Using the adjustable pliers, remove the valve chest assembly (7) from the housing bore.
- k. Remove the valve chest o-rings (315) from the valve chest.
- l. Remove the valve cover o-ring (330) from the housing bore.
- m. To remove the throttle valve kit (11), use adjustable pliers and pull the throttle valve kit from the housing.
- n. Remove the throttle body o-rings (310) from the throttle valve kit (11).
- o. Remove the throttle valve spring (26) from the housing.
- p. If the handle sleeves (25) need replacing, remove them from the housing.

Parts Legend for Paving Breaker
(Refer to Page 3 for Illustration)

- | | | | |
|-----|------------------------|------|--------------------------|
| 1. | Housing | 26. | Throttle Valve Spring |
| 2. | Fronthead | 27. | Anvil Bushing Spring |
| 3. | Backhead | 28. | Fronthead Washer |
| 4. | Piston | 29. | Plunger Spring |
| 5. | Piston Seat | 30. | Piston Seat Retainer |
| 6. | Housing Plug | 31. | Spring Seat |
| 7. | Valve Chest Assembly | 32. | Anvil Bushing Retainer |
| 10. | Throttle Lever | 33. | Flex Handle Connector |
| 11. | Throttle Valve Kit | 100. | Muffler |
| 13. | Air Connection Cap | 200. | Fronthead Bolt |
| 14. | Air Connection Nipple | 205. | Backhead Bolt |
| 15. | Anvil Bushing | 210. | Muffler Bolt |
| 16. | Anvil Bushing Retainer | 300. | Oil Fill Plug O-ring |
| 17. | Latch Kit | 305. | Backhead O-ring |
| 18. | Plunger | 310. | Throttle Body O-ring |
| 19. | Exhaust Deflector | 315. | Valve Chest O-ring |
| 20. | Filter | 320. | Connection Nipple O-ring |
| 21. | Oil Fill Plug | 325. | Connection Cap O-ring |
| 22. | Rubber Plug | 330. | Valve Cover O-ring |
| 23. | Roll Pin Kit | 400. | Backhead Washer |
| 25. | Handle Sleeve | 500. | Fronthead Nut |

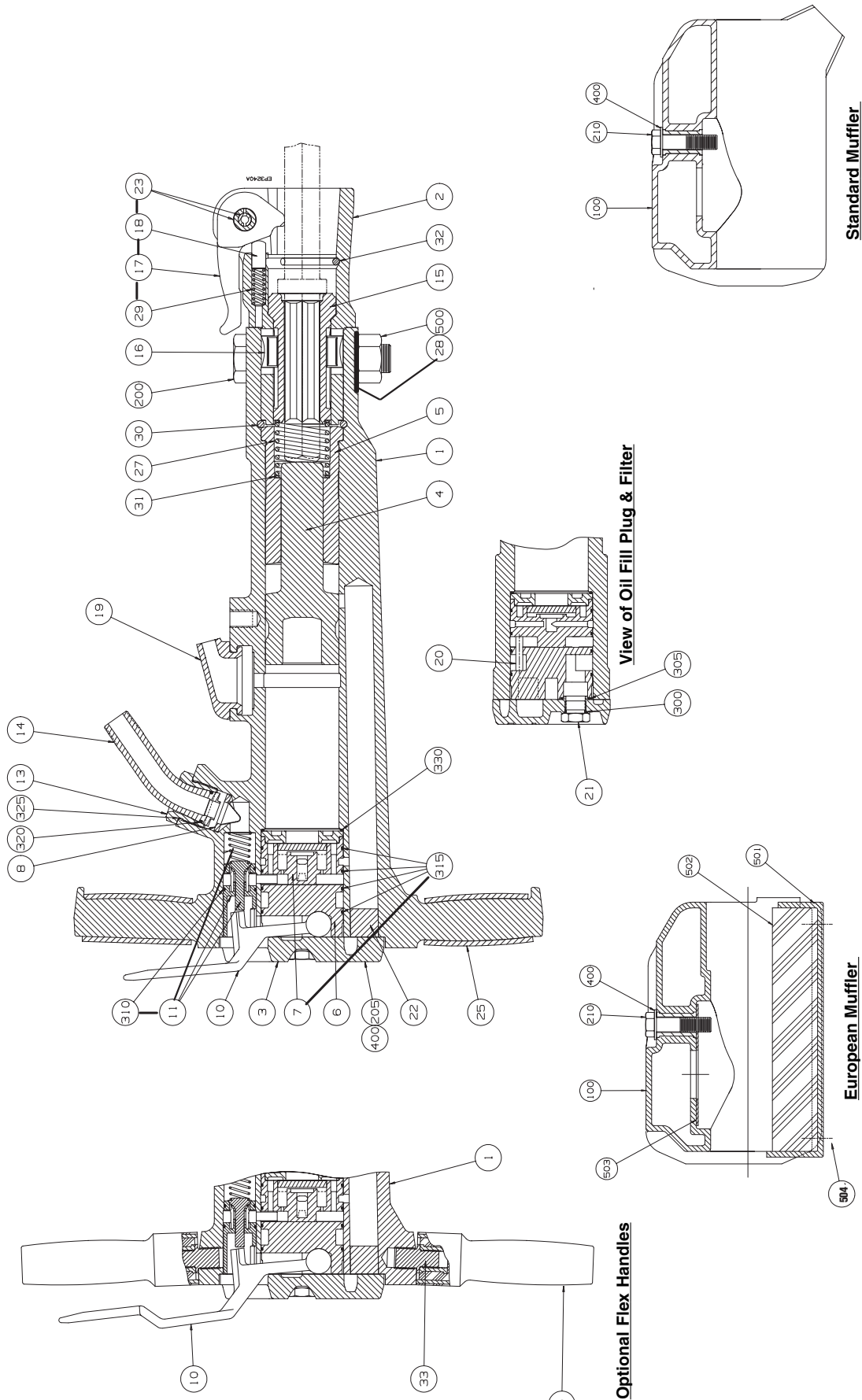

Figure 1

Paving Breaker Models MX60, MX60S & MX90, MX90S – Sectional Illustration
 (For Parts List, refer to Page 2)

q. Although there should never be a need to, the rubber plug (22) may be removed by inserting a screw driver between the plug and the hole bore and prying the plug out.

r. If it becomes necessary to remove any of the air connection parts, unscrew the air connection cap (13) from the housing (1). Slide the air connection nipple (14) back through the cap. If damaged, remove o-rings (320 & 325).

s. If required, use a screw driver to pry the exhaust deflector (19) out of the housing (1).

t. Carefully lay the housing horizontally on the floor. From the fronthead end, tilt the housing so that the piston will come out of the backhead end of the housing. Remove the piston (4) from the housing.

NOTICE

A lifting device is recommended for lifting the paving breaker and putting it into a vise.

u. Position and secure the paving breaker in a vise horizontally.

CAUTION

CLAMP THE PAVING BREAKER HOUSING IN THE AREA OF THE EXHAUST. CLAMP IT FIRMLY, BUT CAREFULLY. THE HOUSING CAN BE CRACKED IF THE VISE IS OVER TIGHTENED.

v. Remove the fronthead bolt (200), fronthead washer (28) and fronthead nut (500) which retain the fronthead to the housing.

NOTICE

The fronthead assembly is a tight fit in the housing bore. It may be necessary to drive a wedge into the housing slot to open the housing bore enough to allow the fronthead assembly to be easily removed.

w. Remove the fronthead assembly (2) from the housing (1).

x. Remove the anvil bushing spring (27) and the spring seat (31) from the fronthead end of the housing (1).

y. If damaged, the piston seat (5) may be removed by:

1. Using a hacksaw, place the saw into the slot in the fronthead end of the housing (1). Cut the piston seat retainer (30). Rotate the retainer with a screwdriver and saw the retainer again. Remove the retainer. Refer to Figure 2.

2. The piston seat (5) is pressed into the housing (1), so the seat will have to be pressed out. Remove the seat through the fronthead end of the housing.



Figure 2.

z. If it is necessary to remove any of the latch parts from the fronthead assembly, drive out the roll pin kit (23), then remove the latch (2), plunger (18) and the plunger spring (29).

aa. To remove the anvil bushing (15), use a screwdriver and pry the anvil bushing retainer (32) out of the fronthead.

NOTICE

Make sure that the anvil bushing retainers (16) are removed before removing the anvil bushing (15).

ab. If equipped with flex handles (25) that require removal, unscrew the flex handles from the housing (1). If damaged, remove the flex handle connectors (33).

4. INSPECTION AND REPAIR. (Figure 1)

⚠ DANGER

WHEN USING ANY SOLVENT TO CLEAN PARTS, MAKE SURE THAT IT MEETS CURRENT SAFETY AND HEALTH STANDARDS, AND THAT IT IS USED IN AN AREA THAT IS ADEQUATELY VENTILATED.

a. Clean all parts in a suitable solvent.

b. All parts in the housing (1), including the valve chest assembly (7) and housing plug (6) must be examined, and all dust or dirt particles removed.

c. Check the valve chest assembly (7) for cracks or chipping. If damaged, replace it.

d. Replace the piston (4) when a .007 in. (.178mm) feeler gauge can be inserted between the piston and the housing bore.

e. Check the throttle valve parts for wear. Make sure the throttle valve is moves freely.

5. REASSEMBLY. (Figure 1)

- a. If the piston seat (5) was removed, a new seat will have to be pressed into the housing (1) from the fronthead end of the housing.
- b. After pressing the piston seat into the housing, install the piston seat retainer (30).
- c. Set the housing in a vertical position so that the fronthead end of the housing is resting on the floor.
- d. Install the piston (4), stem end first, into the backhead end of the housing bore. The piston may require some initially line up before dropping all the way into position.
- e. The valve cover o-ring (330) is installed next.
- f. Install new valve chest o-rings (315) into the grooves on the valve chest assembly (7) O. D.
- g. Install the valve chest assembly (7), stem end pointing up, into the housing.
- h. Install new valve chest o-rings (315) on the O. D. of the housing plug (6).
- i. If the filter (20) was removed from the housing plug, insert a new filter. The filter should protrude from the bottom of the housing plug 3/16 - 1/4 in. (4.8 - 6.4mm).
- j. Install the housing plug (6) into the housing, making sure to lineup the slot in the plug with the slot in the side of the housing bore.
- k. Install a new backhead o-ring (305) onto the top of the housing plug (6).
- l. If the rubber plug (22) was removed, put a thin film of oil on a new plug and insert into the cavity until flush with the top of the hole.
- m. Install the throttle valve spring (26) into the throttle valve hole in the housing (1).
- n. Install new throttle body o-rings (310) on the throttle valve kit (11),
- o. Install the throttle valve into the throttle valve body.
- p. Insert the throttle valve kit (11) into the housing (1). Make sure that the slot in the top of the throttle body lines up with the slot in the housing (1) and the housing plug (6).
- q. Place the throttle lever (10) into the grooves of the housing plug (6) and throttle valve kit (11).
- r. Install the backhead (3) onto the top of the housing and attach with backhead bolts (205) and backhead washers (400). Torque the bolts to 140 ft-lbs (190 Nm).
- s. If the oil fill plug (21) was removed from the backhead (3), install a new oil fill plug o-ring (300) and screw the plug back into the backhead.

CAUTION

CLAMP THE HOUSING FIRMLY BUT CAREFULLY. THE HOUSING CAN BE CRACKED IF THE VISE IS OVER TIGHTENED.

- t. Secure the housing (1) in a vise with soft jaws. Position the housing with the handles pointing up.
- u. Install a new connection cap o-ring (325) into the groove on the air connection cap (13).
- v. Install a new connection nipple o-ring (320) in the groove on the air connection nipple (14). Install the air connection nipple (14) through the air connection cap (13). Screw the assembled air connection cap into the housing (1).
- w. If the fronthead assembly was disassembled, perform the following:
 1. Install the anvil bushing (15) into the fronthead head end of the fronthead (2), making sure to line up the slots on the bushing O. D. with the holes through the sides of the fronthead.
 2. Install the plunger spring (29) and plunger (18) into the plunger hole in the fronthead (2).
 3. Line up the hole in the latch (17) with the hole in the fronthead ear and install the roll pin kit (23).
 4. Insert the anvil bushing retainers (16) into the fronthead holes.
 5. Install anvil bushing retainer (32) into the fronthead (2).
- x. Install spring seat (31) into the fronthead end of the housing (1).
- y. Install the anvil bushing spring (27).
- z. Install the second spring seat (31) into the fronthead, opposite the latch end.

NOTICE

The anvil bushing retainers (16) will have to be held in place while installing the fronthead into the housing.

- aa. The fronthead can now be installed into the housing (1). The latch on the fronthead should be on the same side of the housing as the air connection.
- ab. Install the fronthead bolt (200), fronthead washer (28) and fronthead nut (500). Lubricate the bolt threads and torque the bolt to:
 - MX60 – 250 ft-lb (339 Nm) (3/4in.)
 - MX60 – 240 ft-lb (325 Nm) (7/8in.)
 - MX90 – 375 ft-lb (508 Nm)

ac. Install either the exhaust deflector (19) with a screw driver or install the muffler (100) and retain with the muffler bolt (210) and muffler bolt washer (400).

ad. Install new handle sleeves (25) or the flex handles (25) if so furnished.

6. PERFORMANCE TESTING.

A reconditioned paving breaker should be tested before it is sent back to the job. Before connecting the air hose, check to see that the lubricator used with the breaker is filled with the proper lubricating oil. Refer to IM6085 "Instruction Manual for "PROMAXX"[™] Paving Breaker Models MX60/60S & MX90/90S", Section 5, for the correct lubricating oil specifications.

Pour a small amount (2 to 3 oz. [.06 to .09 L]) of rock drill oil into the breaker inlet, for initial lubrication. With the

breaker against the work surface, the breaker should start with less than 20 psi (1.4 bar) air pressure and with the piston reciprocating smoothly. Let the breaker run in slowly at reduced pressure long enough to see that it is in good working order. If the breaker stalls, turn off the air immediately. Stalling indicates binding caused by tight fits. After a short period of operation, a definite rhythm should develop and an even exhaust note will be heard. The breaker may become warm, but should not overheat. If erratic operation continues or stalling persists, disassemble the breaker and check for binding of parts.

After an initial period of low pressure operation, check the performance of a reconditioned breaker with that of a new one by comparing both under similar conditions and with normal air pressure. Once testing is completed, place plastic caps or plugs in all parts to keep out dirt until the breaker is put back into service.

Alphabetical Index

| Title | Page No. |
|-----------------------|----------|
| INTRODUCTION | 1 |
| TROUBLESHOOTING | 1 |

1.INTRODUCTION.

This section contains detailed information for troubleshooting the "PROMAXX"™ Paving Breaker Models MX60 & MX90.

2. TROUBLESHOOTING.

Troubleshooting will be accomplished by using the appropriate illustration provided in this instruction manual and the step by step trouble and remedy. Using both of these together will solve most common problems.

Table 1. Troubleshooting

| TROUBLE | PROBABLE CAUSE | REMEDY |
|-------------------------------------|--|--|
| Paving breaker will not start. | 1. Plugged exhaust port or air passages caused by dirt or hose particles. 2. Stuck valve due to gummy oil or incorrect assembly. 3. Frozen piston due to improper lubrication. | 1. Dismantle breaker, clean out all ports and air passages. Keep the air hose in good condition; never use a soft deteriorated hose. 2. Remove valve chest parts from the breaker. Clean parts. Never use dirty oil or oil that does not conform to the recommended specifications. 3. Dismantle breaker to remove piston. Repair piston by placing in a high speed lathe and dressing with fine emery cloth. Never run breaker without the proper lubricating oil in the lubricating oil reservoir. |
| Paving breaker loses power rapidly. | 1. Restriction in air supply line. 2. Air supply line too long. 3. Diameter of air supply line too small. | 1. Never allow the air supply to kink or make sharp bends. 2. As a general rule keep the air supply line under 50 ft. (15m). 3. A 3/4 in. (19.1 mm) diameter air supply is recommended for the breaker. |
| Freezing at exhaust ports. | 1. Excessive moisture in the air supply line. | 1. Install moisture traps in the air supply line or add anti-freeze lubricant directly through the air inlet. Use "KILFROST" anti-freeze lubricant or equivalent. |

(Continued)

Table 1. Troubleshooting

| TROUBLE | PROBABLE CAUSE | REMEDY |
|--|---|--|
| Paving breaker lacks power. | <ol style="list-style-type: none"> 1. Low air supply pressure. 2. Running on fronthead cushion. 3. Plugged air passages. 4. Lack of lubricating oil. 5. Sticking valve. | <ol style="list-style-type: none"> 1. The air supply pressure at the tool should be 90 to 100 psi (6.2 to 6.9 bar). 2. Keep shank fed-up to the work. Always maintain a constant pressure when operating the breaker. 3. Dismantle the breaker and clean out all ports and passages. 4. Maintain the proper oil level in the lubricating oil reservoir. Steel shank must show a film of oil. 5. Remove valve chest parts from the breaker. Clean parts. Never use dirty oil or oil that does not conform to the recommended specifications. |
| Overheating of the piston seat on a new machine. | <ol style="list-style-type: none"> 1. Breaker not properly broken in. | <ol style="list-style-type: none"> 1. Stop operating the breaker and perform initial servicing. Never run a new breaker at full throttle until a proper break-in period has been completed. |
| Overheating of the paving breaker after break-in period. | <ol style="list-style-type: none"> 1. Running on fronthead cushion. 2. Piston not hitting the shank because of short shank. 3. Pulling steel at full throttle. 4. Lack of lubrication or im-proper lubricating oil. | <ol style="list-style-type: none"> 1. Keep shank fed-up to work. Always maintain constant pressure when operating the breaker . 2. Remove shank piece from breaker. 3. When pulling steels, always use minimum throttle. 4. Before operating the breaker make sure the lubricating oil reservoir is full of proper lubricant. |
| Erratic or sluggish operation. | <ol style="list-style-type: none"> 1. Lubricating oil too heavy, slowing down valve action. 2. Gummed oil or dirt in operating parts. | <ol style="list-style-type: none"> 1. Use only the recommended lubricating oil. 2. Dismantle breaker and clean out dirt and gummy residue. Service the breaker with clean oil. Protect the tool from dirt when idle. |
| Fogging. | <ol style="list-style-type: none"> 1. Excessive moisture in the air supply line. 2. Over lubrication. | <ol style="list-style-type: none"> 1. Blow out air lines. If moisture traps are installed in the air supply line, drain the moisture. 2. Clean lubricating oil reservoir and adjust for proper rate of feed. |

| Date | Run Time (Hours) | Work Performed | QTY | Work BY |
|------|------------------|----------------|-----|---------|
| | | | | |
| | | | | |
| | | | | |
| | | | | |
| | | | | |
| | | | | |
| | | | | |
| | | | | |
| | | | | |
| | | | | |
| | | | | |
| | | | | |
| | | | | |
| | | | | |
| | | | | |
| | | | | |
| | | | | |
| | | | | |
| | | | | |
| | | | | |
| | | | | |
| | | | | |
| | | | | |
| | | | | |
| | | | | |
| | | | | |
| | | | | |
| | | | | |
| | | | | |
| | | | | |
| | | | | |

“PROMAXX™” Series Paving Breaker

Warranty Policy Statement

INGERSOLL-RAND COMPANY WARRANTS THAT ITS “PROMAXX[®]” SERIES PAVING BREAKERS ARE FREE OF DEFECTS IN MATERIAL AND WORKMANSHIP FOR THE FOLLOWING PERIODS:

- A. MAIN BREAKER HOUSING
& FRONTHEAD CASTING 3 YEARS
- B. ALL OTHER COMPONENTS: 1 YEAR

SHOULD AN INGERSOLL-RAND “PROMAXX™” SERIES PAVING BREAKER PROVE DEFECTIVE DURING THE SPECIFIED WARRANTY PERIODS, INGERSOLL-RAND WILL REPLACE OR REPAIR IT FREE OF CHARGE.

THIS WARRANTY DOES NOT APPLY TO NORMAL WEAR AND TEAR, OR TO UNITS THAT HAVE BEEN MODIFIED, MISUSED, OR REPAIRED IN A MANNER NOT APPROVED BY INGERSOLL-RAND COMPANY. THE OPINION OF INGERSOLL-RAND IN DETERMINING COMPLIANCE WITH THE AFOREMENTIONED CONDITIONS WILL BE FINAL.

Ingersoll-Rand Company

Limitation of Liability

THE REMEDIES OF THE USER SET FORTH UNDER PROVISIONS OF WARRANTY OUTLINED ABOVE ARE EXCLUSIVE AND THE TOTAL LIABILITY OF INGERSOLL-RAND OR ITS DISTRIBUTORS WITH RESPECT TO THIS SALE OR THE EQUIPMENT AND SERVICE FURNISHED HEREUNDER, IN CONNECTION WITH THE PERFORMANCE OR BREACH THEREOF, OR FROM THE SALE, DELIVERY, INSTALLATION, REPAIR OR TECHNICAL DIRECTION COVERED BY OR FURNISHED UNDER THIS SALE. WHETHER BASED ON CONTRACT, WARRANTY, NEGLIGENCE, INDEMNITY, STRICT LIABILITY OR OTHERWISE SHALL NOT EXCEED THE PURCHASE PRICE OF THE UNIT OF EQUIPMENT UPON WHICH SUCH LIABILITY IS BASED.

INGERSOLL-RAND, ITS SUPPLIER(S) AND ITS DISTRIBUTORS SHALL IN NO EVENT BE LIABLE TO THE USER, ANY SUCCESSORS IN INTEREST OR ANY BENEFICIARY OR ASSIGNEE RELATING TO THIS SALE

FOR ANY CONSEQUENTIAL, INCIDENTAL, INDIRECT, SPECIAL OR PUNITIVE DAMAGES ARISING OUT OF THIS SALE OR ANY BREACH THEREOF, OR ANY DEFECTS IN, OR FAILURE OF, OR MALFUNCTION OF THE EQUIPMENT UNDER THIS SALE WHETHER BASED UPON LOSS OF USE, LOST PROFITS OR REVENUE, INTEREST, LOST GOODWILL, WORK STOPPAGE, IMPAIRMENT OF OTHER GOODS, LOSS BY REASON OF SHUTDOWN OR NON-OPERATION, INCREASED EXPENSES OF OPERATION OF THE EQUIPMENT, COST OF PURCHASE OF REPLACEMENT POWER OR CLAIMS OF USERS OR CUSTOMERS OF THE USER FOR SERVICE INTERRUPTION WHETHER OR NOT SUCH LOSS OR DAMAGE IS BASED ON CONTRACT, WARRANTY, NEGLIGENCE, INDEMNITY, STRICT LIABILITY OR OTHERWISE.

Worldwide Ingersoll-Rand sales offices

U.S.A.

U.S. C&M OFFICES

Bethlehem, PA 18017-2293
1495 Valley Center Pkwy.
215/882-8800

Boston, MA 02125
33 Locust Street
617/288-8988

Casper, WY 82601
3273 N. I-25 Frontage Road
307/237-4259

Denver, CO 80207
5805 East 39th Ave.
303/399-1580

East Hanover, NJ 07936
98 Route #10
201/887-1212

Elkridge, MD 21227
5681 Main Street
410/796-3200

Gray, TN 37615
Suncrest Drive
615/477-3114

Houston, TX 77001
2210 McAllister
713/681-9221

Knoxville, TN 37922 (C&M)
112 Glenleigh Court
Suite #1
615/966-8800

Knoxville, TN 37912 (RES)
4726 Clinton Hwy.
615/525-0404

Milwaukee, WI 53225
12311 West Silver Spring Dr.
414/461-7810

Nashville, TN 37229
310 S. Second St.
615/254-1811

New Castle, DE 19702
91 Christiana Road
302/324-9040

New Cumberland, PA 17070
Exit 15 on Rt. 83
4 miles south of Harrisburg
717/938-1441

New England
300 Turnpike Rd. – Route 9
Southboro, MA 01772
508/481-1350

Philadelphia
Route 309
Montgomeryville, PA 18936
215/855-9990

Phoenix, AZ 85007
820 N. 17th Ave.
602/258-6493

Pico Rivera, CA 90660
5211 Paramount Blvd.
310/948-3801

Portland, OR 97214
240 South East Clay Street
503/232-0151

Sacramento, CA 95836
1851 Bell Avenue
916/641-1994

San Leandro, CA 94577
1944 Marina Blvd.
510/357-9131

Scranton, PA 18505
605 Davis St.
717/346-3885

Seattle, WA 98168
11222 E. Marginal Way S.
206/762-7400

U.S. C&M FACTORIES ROCK DRILLS

Rotary blasthole deephole, Monitoring rigs

Ingersoll-Rand Co.
Rotary Drill Division
2100 N. First St.
Garland, TX 75040
214/495-8181

Downhole Drills and Bits; Pneumatic And Hydraulic Crawler Drills; Anchor Drills; Breakers and Jackhammers™

Ingersoll-Rand Co.
Rock Drill Division
7500 Shadwell Drive
Roanoke, VA 24019-5198
703/362-3321

COMPACTORS, PAVING MILLERS, ASPHALT PAVERS AND FORKLIFTS

Ingersoll-Rand Co.
Road Machinery Division
Ingersoll Drive
Shippensburg, PA 17257
717/532-9181

UNDERGROUND EQUIPMENT

Roadheaders; drill jumbos, diesel- powered production and utility equipment (scoops, haul dumps, etc.)

Contact Rock Drill Division
Roanoke, VA

Split Set Rock Stabilizers

Simmons-Rand Co.
Split Set Division
Suite 300
100 Thanet Circle
Princeton, NJ 08540-3662
609/921-8688

AIR COMPRESSORS

Portable compressors, Generator Sets and Light Plants

Ingersoll-Rand Co.
Portable Compressor Division
P.O. Box 868
501 Sanford Ave.
Mocksville, NC 27028
704/634-3561

Small Compressor Plant

Ingersoll-Rand Co.
101 Industrial Drive
Campbellsville, KY 42718
502/465-3511

Centrifugal compressors (Centac)

Ingersoll-Rand Co.
Centrifugal Compressor Division
Route 45
Mayfield, KY 42066
502/247-8640

Reciprocating and rotary-screw compressors

Ingersoll-Rand Co.
P.O. Box 656
Allentown, PA 18105
215/433-6411

PUMPS

Engineered centrifugal pumps

Ingersoll-Rand Co.
P.O. Box 486
Phillipsburg, NJ 08865
201/859-7000

Vertical turbine pumps

Ingersoll-Rand Co.
Vertical Turbine Pump Division
Hastings, NE 68901
402/463-1306

TOOLS, WINCHES

Ingersoll-Rand Co.
Power Tool Division
P.O. Box 1776
Liberty Corner, NJ 07938
201/647-6000

LIQUID/SOLID SEPARATORS

Ingersoll-Rand Co.
Impco Division
150 Burke St.
Nashua, NH 03061
603/882-2711

CANADA

Surface and underground equipment Tools and industrial equipment

Ingersoll-Rand Canada Inc.
2360 Millrace Court
Mississauga, Ontario L5N1W2
(1) 416/858-8480

Ingersoll-Rand Canada Inc.
2250 Hymus Blvd.
Dorval, Quebec H9P1J9
(1) 514/683-9157

MEXICO

All equipment

Ingersoll-Rand, S.A. de C.V.
Boulevard Centro
Industrial #11
Fracc. Industrial
Puente de Vigas
Tlalnepantla,
54090 Edo, de Mexico
Mexico
52 (5) 390-40-21
52 (5) 390-24-11

SOUTH AMERICA

USA, Miami, Florida
1 (305) 599-0500

Chile – Santiago
56 (2) 41-198

Colombia – Bogota
57 (1) 219-1406/1460

Venezuela – Caracas
58 (2) 239-9369

EUROPE

Austria – Vienna
43 (222) 83-05-250

Belgium – Brussels
32 (02) 216-99-95

France – Trappes
33 (3) 050-61-10

Germany – Ratingen
49 (2102) 48090

*Italy – Milano
39 (02) 950561

Netherlands – Zoeterwoude
31 (071) 452200

Norway – Oslo
47 (02) 39-15-26

Spain – Madrid
34 (9) 1-671-07-00

Sweden – Spanga
46 (08) 750-59-20

United Kingdom – London
44 (01) 584-5070

* Also for Bulgaria, Czechoslovakia,
Hungary, Poland, Rumania, USSR,
Yugoslavia.

AFRICA – MIDDLE EAST

Egypt – Cairo
(02) 341-5190

South Africa – Alrode
27 (011) 864-3930

ASIA-PACIFIC

Australia – Melbourne
61 (3) 794-1611

Hong Kong
852 (5) 270183

India – Bombay
91 (22) 4936765

Japan – Tokyo
81 (3) 403-0841/7

Korea – Seoul
82 (2) 776-2541

New Zealand – Auckland
64 (9) 885096

Philippines – Manila
63 (2) 89-85-06/08

Singapore
(65) 8611555