

SERVICE INSTRUCTIONS

Tools Renewed Inc.
800-247-3639
Fax
860-665-9821
www.toolsrenewed.com

Henry Tools
MODELS
65 V
65 VS

TC Service
Model 66VL,
66VLS

DISASSEMBLY

1. Disconnect air and remove all wheels and accessories from grinder.
2. Secure the dead handle (550.1-C) of the grinder in a vice.
Remove the three socket head screws (700-47A) and remove wheel guard.
3. Grasp the wheel flange (550.12A) and pull the complete motor assembly from the case. If the case is too tight, put 5/5-11 hex nut on shaft and grip firmly in vise; using soft hammer, remove case assembly by tapping alternately at live and dead handle joints.
4. Put the flats of the wheel flange in the vise and remove governor. (NOTE: LEFT HAND THREAD)
5. Remove lock ring (1000-5). Holding the cylinder (700-11) in the left hand, place a long tap pin in the hole left by the removal of the governor. With a small hammer, tap lightly on the end of this pin, which separates the spindle (650.5) from the rear bearing (700-0) and the rear thrust (700-16).
Remove cylinder (700.11), rotor blades (700.13) and rotor (700-12). Do not remove key (700-15) at this time.
7. Clamp spindle holder in vise vertically. Line up the keyway in the holder and slide the spindle assembly through. Remove wheel flange (right hand thread) with suitable wrench.
5. Remove spindle assembly from vice or holder. Remove key and press spindle out of bearing support. (550-1-BTB). Support bearing (700.7) and press spindle through. 9. Remove 550.21 snap ring with snap ring pliers. Remove spacer 550-25 and bearing 700-7.
10. To check throttle (valve, unscrew plug (700-2.20) and lift out valve spring (600-51) and plunger (550-13). Remove the "b" ring (200-0) with a sharp tool and replace with a new ring.

RE-ASSEMBLY

1. Seat (700-7) bearing in bearing support (650-1-BTB), place 550-25 spacer rounded edges facing toward bearing and secure with 550-21 snap ring.
2. Press spindle into bearing support & through the (700.7) bearing.
3. Place key (700-15) into spindle keyway. 4. Clamp spindle holder in vise vertically. Line up the keyway in the holder end slide the assembly through.
5. Thread wheel flange (550-12-A) clockwise by hand until wheel flange bottoms on bearing. Tighten down with suitable wrench. Remove assembly from spindle holder.
Clamp wheel flange in vise.
0. Line up cylinder pin holes in the bearing support (050.1-BTS) and the front thrust (700-10).
7. Put key (700-15) in spindle keyway and slide rotor (700-12) down arbor and insert blades (700-13). Put cylinder (700-11) into place (NOTE: Numerous holes on top of cylinder face upwards toward you).
10. Slip rear bearing (700-9) in rear thrust (700-16) and press on spindle. (Press on inner race of bearing.) Be sure that short dowel pin in cylinder goes into hole in rear thrust (700-16).
11. Put lock ring (1000-5) on spindle. (There is no groove.)
12. Prior to reassembly inspect governor for gouges, nicks or dents.
Screw governor tight in rear spindle. (NOTE: THIS IS LEFT HAND THREAD)
Oil governor and inside of motor.
13. Assemble live handle; add live and dead handles to case; place gasket (650-13) in rear face of case.
14. Drop motor assembly package in case and line up holes in front bearing support with those in front of case.
15. Line up guard with motor holes. Install the three bolts (700-47A) and lockwashers (700-46). Tighten bolts down until snug then back off 1/2 turn.
16. Connect tool to air supply and apply air in several short bursts.
17. Now run tool and tighten down bolts evenly. (Alternating from corner to corner).

18. CHECK RPM WITH A RELIABLE TACHOMETER. TOOL MUST RUN AT OR BELOW SPEED THAT IS STAMPED ON THE TOOL.

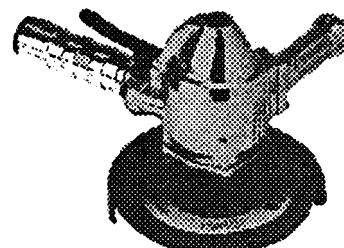
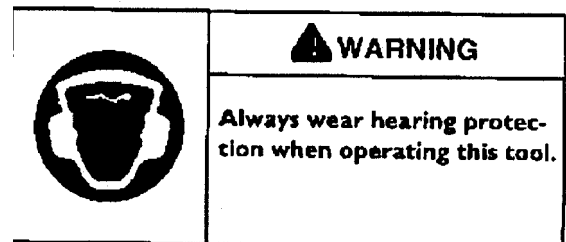
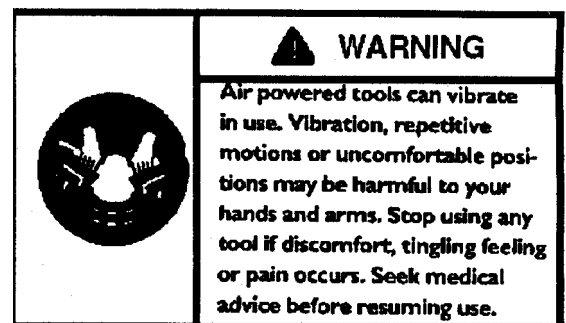
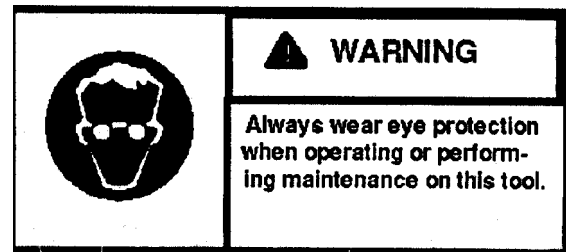

Wheel Mounting Instructions

Wheels known to have been subjected to improper mounting procedures can burst violently and should be destroyed rather than risk their use by someone who may not notice that the wheels are damaged.

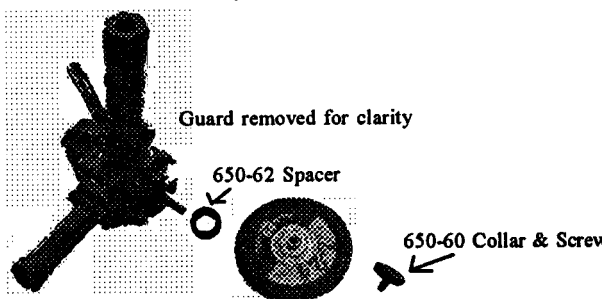

WARNING: FRAGMENTS FROM AN ABRASIVE WHEEL THAT BREAKS OR COMES APART WHILE ROTATING CAN CAUSE SERIOUS INJURY OR EVEN DEATH. NEVER OPERATE A WHEEL TYPE GRINDER WITHOUT A GUARD.

Note: The grinding wheel shown above has threaded hub.

Driving flange spacer 650-62 flat side faces wheel.

Note: the 650-62 & 650-60 is shipped STANDARD on your model 65V Grinder.

Your new 65V Vertical grinder flanges must be flat, not relieved, and free of nicks or burrs. Flanges for Type 6 or 11 wheels must be at least 1/3 the wheel diameter. Always use wheel retainer supplied by manufacturer on Type 6 or 11 wheels (Cup Wheels). When using depressed center wheels, only use adapters supplied by the manufacturer unless they are furnished as a part of the wheel. Do not reuse throwaway adapters attached to depressed center wheels by the manufacturer. Spindles must not be bent and threads must be free of any damage that might keep a wheel from being centrally mounted or seated properly against driving flange. Wheel must be sufficiently tightened to prevent spin-off. Before using or after mounting wheel, the tool must be run for one minute in a protected enclosure to check integrity of the wheel.

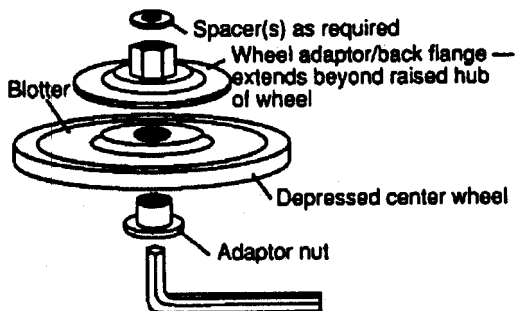

Part No. 849269 Depressed Center Wheel Kit Shown left

Note: This kit must be purchased as an optional Accessory.

INSPECT THE WHEEL OR ACCESSORY

Check the maximum safe RPM marked on the wheel or accessory. **Never use a wheel or accessory rated below the actual tool speed.** Cracked, dropped, faulty, or bent accessories are dangerous. Suspect accessories should not be used and should be disposed of. Inspect wheel for cracks or chips, water stains, or signs of abuse or improper storage. Cracked or faulty grinding wheels are dangerous. They must be destroyed rather than risk their use by someone who may not notice that they are damaged.

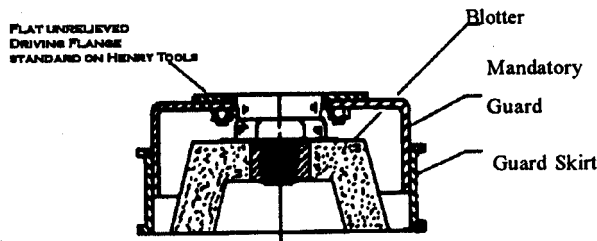

TYPE 11 WHEELS
(Cup Wheels)



Tools Renewed Inc.
800-247-3639
Fax
860-665-9821
www.toolsrenewed.com

MODELS
65 V
65 VS

What kind of Front Bearing Support do you have??

NEW FOR

NEW STYLE

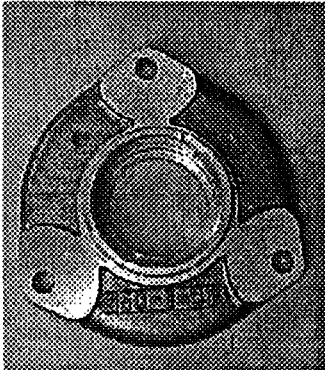

700-7
Bearing

550-25
Spacer



550-21
snap ring

650-1-BTB
or
650-1B or 650-1-BTN

NEW STYLE

Highly Recommended new style bearing support makes it easier to repair your tool. (Shown above).

OLD STYLE

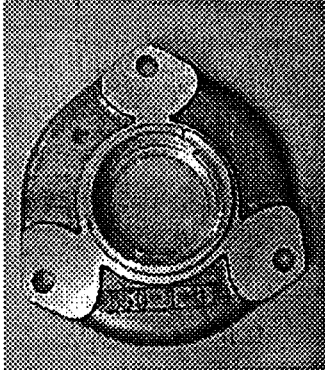

700-7
Bearing

700-6
Lock Nut

700-49
Set Screw

650-1-BT
Note: This Plate has
Threads

OLD STYLE

TC SERVICE
MODEL 66VL, 66VLS

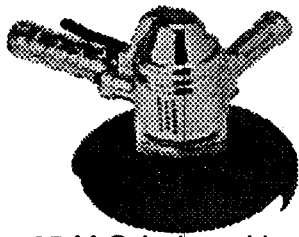

65 V Grinder with
9" Wheel Guard

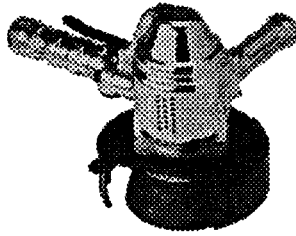

65 V Grinder
with 6" Cup Guard

Tools Renewed Inc.
 800-247-3639
 Fax
 860-665-9821
 www.toolsrenewed.com

Henry Tools

MODELS
65 V
65 VS

GUARDS & ACCESSORIES

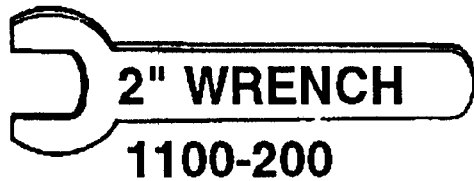

700-200 (7" Guard)
 700-201 (9" Guard)

SPIRALCOOL PADS

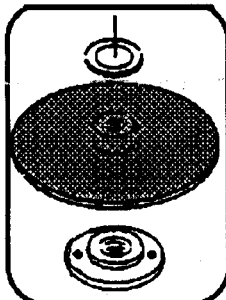
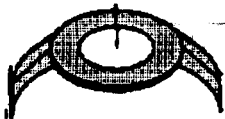

412988
(6" Cup Guard)

849914 (9" Pad)
 849913 (7" Pad)
 849259 Nut

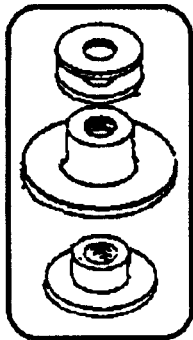

849269
(Depressed Whl. Adapt. Kit)

ACCESSORIES

REPAIR KIT FOR 65V GRINDER

Part # 510124
 Includes:

- 1 700-7 Bearing
- 1 700-9 Bearing
- 4 700-13 Rotor Blades
- 1 650-1-BTG (3 Hole Gasket)
- 1 650-13 Gasket
- 1 1000-5 Snap Ring

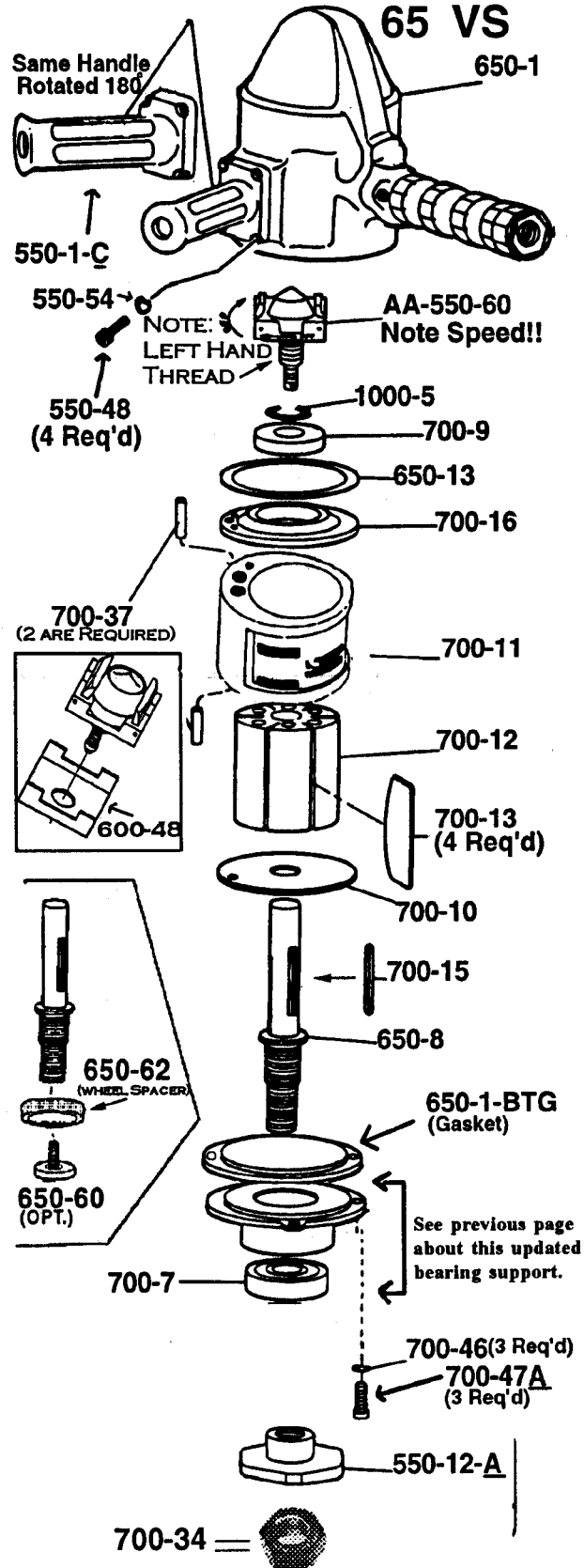

Tools Renewed Inc.

800-247-3639

Fax

860-665-9821

www.toolsrenewed.com

LIVE HANDLE ASSEMBLY

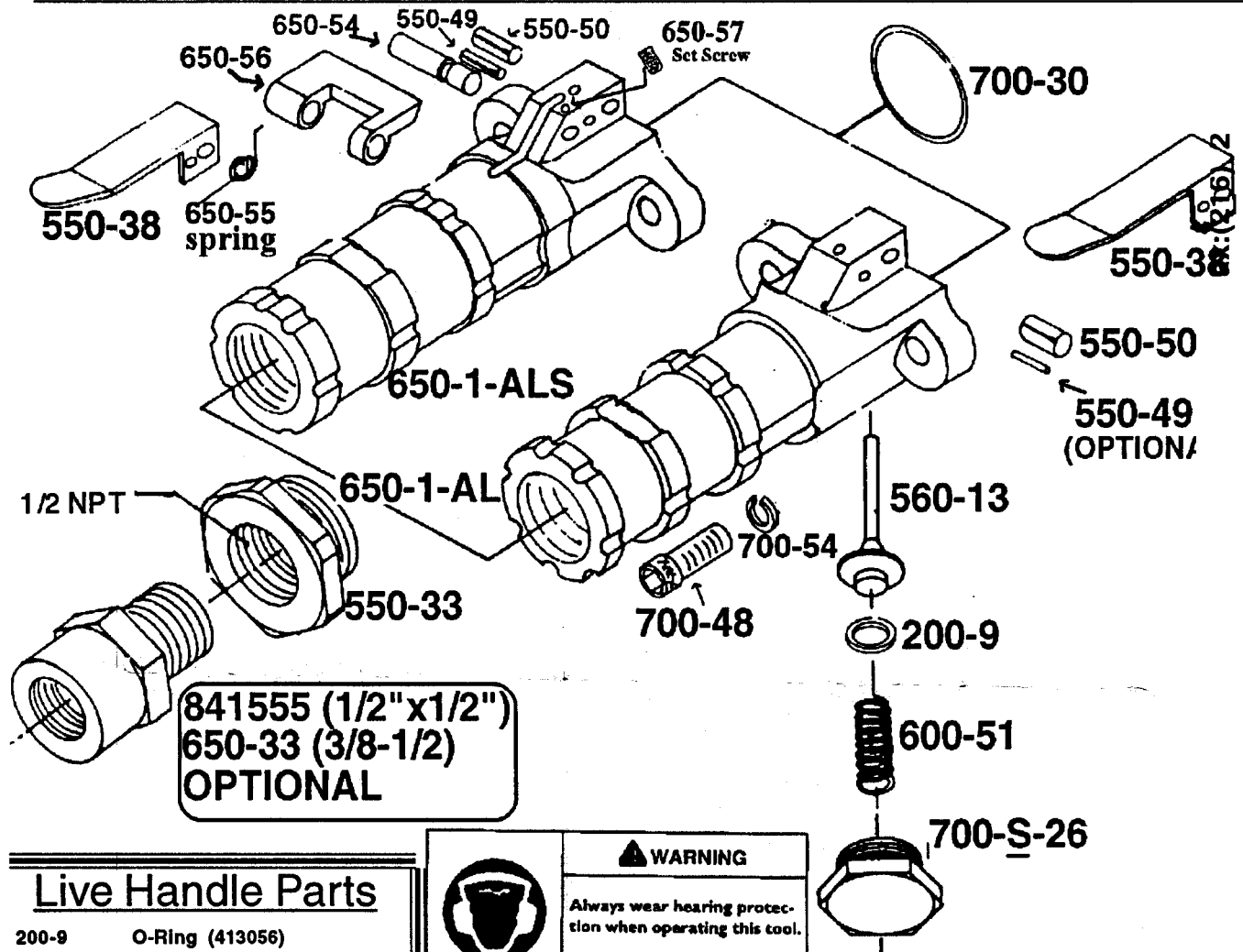

Live Handle Parts

200-9	O-Ring (413056)
550-33	Adapter Cap(412977)
550-38	Lever (412977)
550-49	Pin (842320) (T.Lev.) (OPTIONAL)
550-50	Pin (1/4x1")
560-13	Thr. Valve Assembly
600-51	Plunger Spring
650-1-AL	Valve Body (Lev.Handle)(LIVE HANDLE)
650-1-ALS	Valve Body(Lev.Handle)(SAFETY HANDLE)
650-33	Screen Handle Bushing 1/2Mx3/8F
650-54	Pin for Safety Handle
650-55	Spring for Safety Handle
650-56	Lock out for Safety Handle
650-57	Set Screw
700-30	"O"-Ring
700-48	Cap Screw (For Live Handle)(2 Reqd)
700-54	Lock Washer (High Collar)(2 reqd)
700-S-26	Plug (413290) (Thr. Valve)
841555	Screen Handle Bushing 1/2x1/2

Live Handle Assembly Complete
Part # AA-650-1-AL
Part # AA-650-1-ALS (SAFETY LO

