

Tools Renewed Inc  
Tel: 800-247-3639 Fax: 860-665-9821  
Email: sales@toolsrenewed.com

Spare parts list  
Liste de pièces de rechange  
Ersatzteilliste  
Lista de piezas de repuesto  
Lista de peças  
Listino ricambi  
Onderdelenlijst  
Καταλογος ανταλλακτικῶν  
Varaosu luettelo  
Reservdelssliste  
Reservdelfortegnelse  
Reservdelsförteckning

**Rock drills**  
**Marteaux-perforateurs**  
**Gesteinsbohrhämmer**  
**Perforadoras**  
**Martelo perfuradoras**  
**Perforatrici**  
**Boorhamers**  
**Αεροσθρεσ**  
**Kallioporakoneet**  
**Bjergboremaskiner**  
**Bergboremaskiner**  
**Bergbormaskiner**

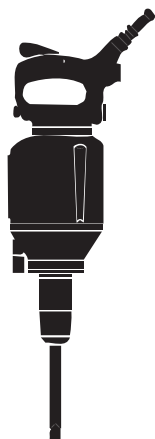

**BBD 12D**  
**BBD 12D-01**  
**BBD 12Ds**  
**BBD 12DS-01**  
**BBD 12DC**  
**BBD 12DCS**

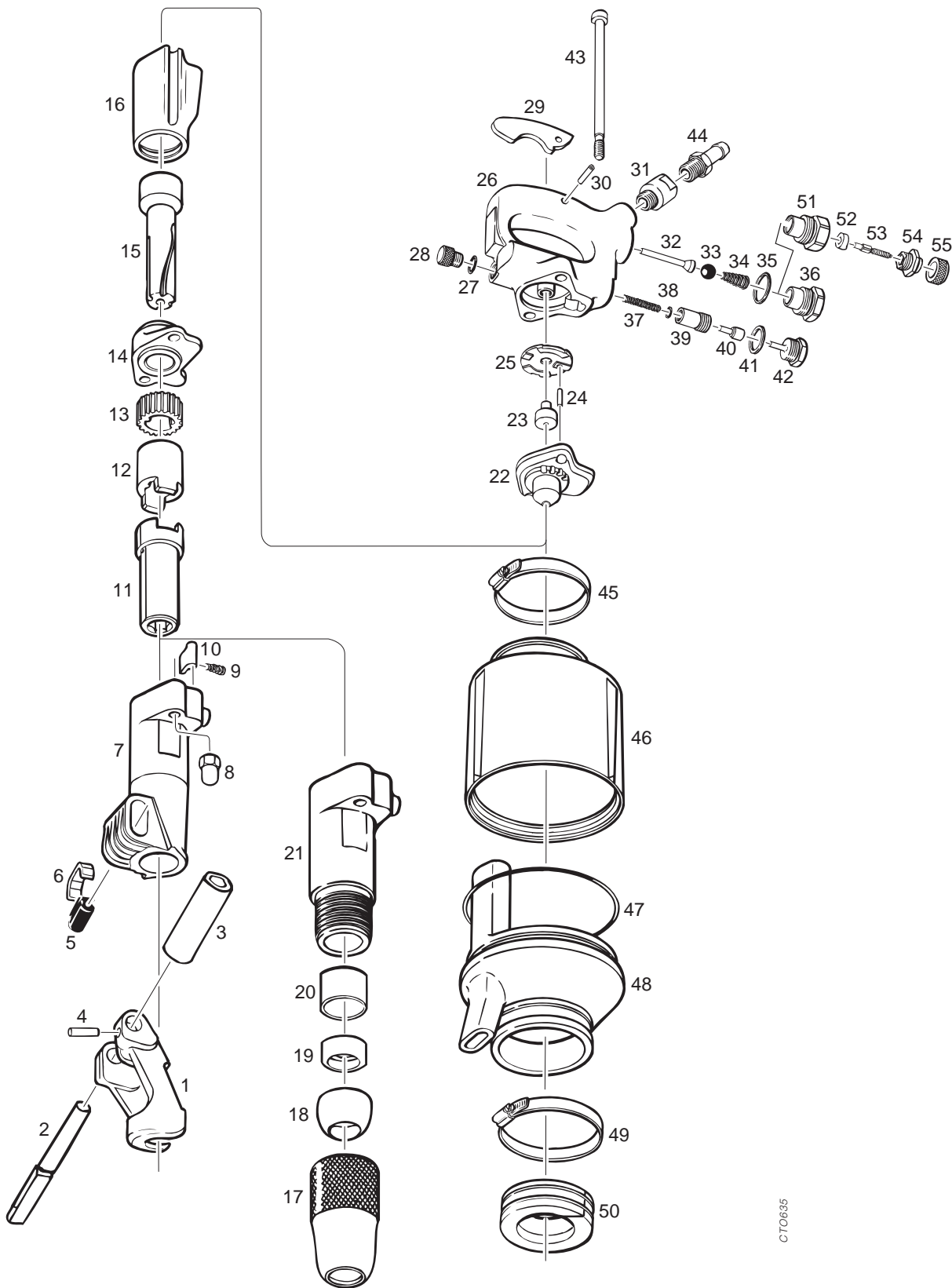

CTO635

Fig. No. No. de fig. Abb. Nr. Núm. de fig. Fig. No No rif. Fig nr. Αριθ Σχ. Kuva nr. Fig. nr. Fig. nr. Fig. nr.	Ordering No. Référence Bestellnummer Núm. pedido Encomenda No No. Cat. Bestel nr. Αριθ. Παραγγελίας Tilaus nro. Bestillingsnummer Bestillingsnummer Best. nummer	Quantity Quantité Anzahl Cantidad Qvantidade Quantità Aantal Ποσότητα Lukumäärä Antal Antall Antal	Description	Dimensions Dimensions Abmessungen Dimensiones Dimensões Dimensioni Afmetingen Διαστάσεις Mitat Dimensioner Dimensioner Dimensioner
--	---	---	-------------	---

		D	D-01	DS	DS-01	DC	DCS		
1	3115 2475 00	1	1	1	1	-	-	Drill retainer	
2	3115 2480 00	1	1	1	1	-	-	Retainer pin	
3	3115 2481 00	1	1	1	1	-	-	Sleeve	
4	0108 1359 00	1	1	1	1	-	-	Slotted spring pin	Ø8x32 mm
5	3111 0057 00	1	1	1	1	-	-	Rubber buffer	
6	3111 0056 00	1	1	1	1	-	-	Buffer plate	
7	3111 0053 00	1	1	1	1	-	-	Front head	
8	3111 0031 00	2	2	2	2	2	2	Cap nut	
9**	3111 0023 00	2	2	2	2	2	2	Conical spring	
10**	3111 0020 00	2	2	2	2	2	2	Pawl	
11	3111 0051 00	1	-	1	-	1	1	Drill chuck	⬡ 19x108 mm
11	3111 0066 00	-	1	-	1	-	-	Drill chuck	⬡ 22x108 mm
12	3111 0024 00	1	1	1	1	1	1	Driver	
13	3111 0019 00	1	1	1	1	1	1	Ratchet wheel	
14	3111 0017 00	1	1	1	1	1	1	Intermediate part	
15	3111 0016 00	1	1	1	1	1	1	Piston	
16	3111 0015 00	1	1	1	1	1	1	Cylinder	
17	3111 0026 00	-	-	-	-	1	1	Drill retainer	
18	3115 1250 00	-	-	-	-	1	1	Buffer	
19	3111 0028 00	-	-	-	-	1	1	Stop ring	
20	3115 1249 00	-	-	-	-	1	1	Sleeve	
21	3115 1240 00	-	-	-	-	1	1	Front head	
	3111 0013 80	1	1	1	1	1	1	Cover compl.	
22	— *)	1	1	1	1	1	1	– Cover	
23	3111 0014 00	1	1	1	1	1	1	– Guide pin	
24	0108 3241 00	1	1	1	1	1	1	– Pin	Ø4x22 mm
25	3111 0012 00	1	1	1	1	1	1	Main valve	
	3111 0001 80	1	1	1	1	1	1	Handle, compl.	
26	— *)	1	1	1	1	1	1	– Handle	
27	0663 2120 00	1	1	1	1	1	1	– O-ring	Ø13,3x2,4 mm
28	3111 0007 00	1	1	1	1	1	1	– Plug	
29	3111 0002 00	1	1	1	1	1	1	– Trigger	
30	0108 1327 00	1	1	1	1	1	1	– Pin	Ø6x26
31	3510 0143 00	1	1	1	1	1	1	– Nut	
32	3111 0003 00	1	1	1	1	1	1	– Valve pin	
33	3111 0196 00	1	1	1	1	1	1	– Rubber ball	
34	3111 0004 00	1	1	1	1	1	1	– Conical spring	
35	3111 0010 00	1	1	1	1	1	1	– Washer	
36	3111 0005 00	1	1	1	1	1	1	– Ball retainer	

\*\* Included in pawl set 3115 9202 90/ Inclus dans kit de blocage 3115 9202 90/ Im Klanensatz enthalten 3115 9202 90/ Forma parte del juego de trinquete 3115 9202 90/ Incluído no conjunto de bloqueio 3115 9202 90/ Inclusi net kit di blocco 3115 9202 90 / Maakt deel uit van de vergrendelset 3115 9202 20/ Συμπεριλαμβάνεται στο συγκρότημα καστάκιων 3115 9202 90/ Sisältyy pidikesarjaan 3115 9202 90/ Inkluderet i spærrepal-sættet 3115 9202 90/ Inkludert i sperrehasesett 3315 9202 20/ Ingår i spärrset 3115 9202 90

Tools Renewed Inc  
Tel: 800-247-3639 Fax: 860-665-9821  
Email: sales@toolsrenewed.com

Fig. No. No. de fig. Abb. Nr. Núm. de fig. Fig. No No rif. Fig. nr. Ariu Sx. Kuva nr. Fig. nr. Fig. nr. Fig. nr.	Ordering No. Référence Bestellnummer Núm. pedido Encomenda No No. Cat. Bestel nr. Ariu. Paragelías Tilaus nro. Bestillingsnummer Bestillingsnummer Best. nummer	Quantity Quantité Anzahl Cantidad Quantidade Quantità Aantal Posóthta Lukumäärä Antal Antall Antal	Description	Dimensions Dimensions Abmessungen Dimensiones Dimensões Dimensioni Afmetingen Diastáseiw Mitat Dimensioner Dimensioner Dimensioner
---	--	---	-------------	---

		D	D-01	DS	DS-01	DC	DCS		
37	3006 4655 00	1	1	1	1	1	1	– Cyl.spring	
38	0663 2114 00	1	1	1	1	1	1	– O-ring	Ø7,3x2,4 mm
	3111 0008 80	1	1	1	1	1	1	– Valve housing,compl.	
39	— *)	1	1	1	1	1	1	– – Valve housing	
40	— *)	1	1	1	1	1	1	– – Oil valve	
41	3111 0011 00	1	1	1	1	1	1	– Washer	
42	3111 0006 00	1	1	1	1	1	1	– Stop screw	
43	3111 0197 00	2	2	2	2	2	2	Side bolt	
44	9000 0244 00	1	1	1	1	1	1	Hose nipple	
	8092 0104 49	-	-	1	1	-	1	Silencer,compl.	
45	0347 6117 00	-	-	1	1	-	1	– Hose clamp	Ø87-102mm
46	3115 0771 00	-	-	1	1	-	1	– Silencer,upper part	
47	0663 6151 00	-	-	1	1	-	1	O-ring	Ø134,5x3,0mm
48	3115 0772 00	-	-	1	1	-	1	– Silencer,lower part	
49	0347 6116 00	-	-	1	1	-	1	– Hose clamp	Ø77-87mm
50	3115 0773 00	-	-	1	1	-	1	– Bushing	

**Optional equipment/ Equipement en option/ Sonderzubehör/ Equipos opcionales/ Equipamento opcional/ Attrezzatura opzionale/ Extra uitrusting/ Σετ γενικής επισκευής/ Lisävarusteet/ Ekstra udstyr/ Ekstra utstyr/ Extra utrustning**

	3111 0034 81	1	1	1	1	1	1	Reducing device,compl.	
51	— *)	1	1	1	1	1	1	-Ball retainer	
52	3111 0038 00	1	1	1	1	1	1	-Washer	
	— *)	1	1	1	1	1	1	-Valve	
53	— *)	1	1	1	1	1	1	—Valve pin	
54	— *)	1	1	1	1	1	1	—Adapter	
55	— *)	1	1	1	1	1	1	—Hand wheel	

**Synthetic oil AIR-OIL/ Huile synthétique AIR-OIL/ Synthetisches Öl AIR-OIL/ Aceite sintético AIR-OIL/ Sintético óleo AIR-OIL/ Olio sintetico AIR-OIL/ Synthetische olie AIR-OIL/ Συνθετικό λάδι AIR-OIL/ Syn-teettinen öljy AIR-OIL/ Syntetisk olie AIR-OIL/ Syntetisk olje AIR-OIL/ Syntetisk olja AIR-OIL**

	8099 0202 40							Air oil bottle	0.2 l
	8099 0202 36							Air oil bottle	1 l
	8099 0202 02							Air oil container	5 l
	8099 0202 20							Air oil container	25 l
	8099 0202 28							Air oil barrel	200 l

\*) Not delivered separately/ Non disponible en pièces de rechange/ Nicht separat lieferbar/ No se entrega como repuesto/ Non fornibile separatamente/ Não é vendido/ Niet afzonderlijk leverbaar/ Δεν παρέχεται ξεχωριστά/ Ei toimiteta erikseen/ Leveres ikke separat/ Leveres ikke som reservdel/ Levereras ej som reservdel

*Use only authorized parts. Any damage or malfunction caused by the use of unauthorized parts is not covered by Warranty or Product Liability.*

*N'utiliser que des pièces approuvées. Tout endommagement ou fonctionnement défectueux résultant de l'utilisation de pièces non approuvées n'est pas couvert par Garantie et responsabilité du produit.*

*Nur Zugelassene Teile verwenden. Schäden oder Funktionsstörungen, die auf die Verwendung nicht zugelassener Teile zurückzuführen sind, fallen nicht unter die Garantie- oder Produkthaftungsbestimmungen.*

*Sólo se pueden usar piezas autorizadas. Cualquier daño o funcionamiento defectuoso causado por el uso de piezas no autorizadas no se cubre por la Garantía o la Responsabilidad del Producto.*

*Use apenas peças autorizadas. Qualquer avaria ou mau funcionamento motivado pelo uso de peças não é coberto por garantia ou responsabilidade de riscos causados pelo produto.*

*Usare solamente parti autorizzate. I danni o disturbi del funzionamento causati dall'uso di parti non autorizzate, non sono coperti dalla Garanzia né dall'Assicurazione del prodotto.*

*Gebruik uitsluitend geautoriseerdeonderdelen. Schade of gebreken veroorzaakt door het gebruik van niet-geautoriseerde onderdelen vallen niet onder de garantie of de aansprakelijkheid.*

*Χρησιμοποιείτε μόνο εγκεκριμένα εξαρτήματα. Τυχόν καταστροφή ή βλάβη η οποία προκαλείται από τη χρήση μη εγκεκριμένων εξαρτημάτων δεν καλύπτεται από την Εγγύηση ή την Ευθύνη Προϊόντος.*

*Käytä vain hyväksytyjä varaosia. Takuu ja tuotevastuu eivät korvaa hyväksymättömien varaosien käytöstä aiheutuvia vaurioita tai toimintahäiriötä.*

*Brug kun autoriserede dele. Enhver skade eller fejlfunktion, der skyldes brugen af ikke-autoriserede dele, er ikke dækket af garantien eller produktansvarsforsikringen.*

*Bruk bare godkjente deler. Enhver skade eller funksjonsfeil som skyldes bruk av ikke godkjente deler dekkes ikke av garanti eller produktansvar.*

*Använd endast godkända reservdelar. Skada eller funktionsfel som beror på användning av ej godkända reservdelar täcks inte av garantiåtaganden eller produktansvar.*

*Any unauthorized use or copying of the contents or any part thereof is prohibited. This applies in particular to trademarks, model denominations, part numbers and drawings.*

*Toute utilisation ou reproduction non autorisée du contenu, ou d'une partie du contenu, est illicite. Cela s'applique particulièrement aux marques déposées, aux désignations de modèles, aux numéros de pièces et aux plans.*

*Unbefugter Gebrauch oder das Kopieren des Inhalts, auch auszugsweise, ist verboten. Dies gilt besonders für Warenzeichen, Modellbezeichnungen, Teilnummern und Zeichnungen.*

*Está prohibido cualquier uso o copia no autorizada del contenido o de cualquier parte de éste. Esto se aplica en especial a marcas registradas, denominaciones de modelos, números de piezas y dibujos.*

*Qualquer utilização não autorizada ou cópia de qualquer peça é expressamente proibida. Isto aplica-se em particular às marcas registradas, denominação dos modelos, referência de peças e desenhos.*

*E' vitata qualsiasi forma d'uso o copiatura non autorizzata del contenuto, anche parziale, con particolare riguardo ai marchi di fabbrica, alle denominazioni dei modelli, ai numeri delle parti ed ai disegni.*

*Niet-geautoriseerd gebruik of kopiëren van de inhoud of een deel daarvan is niet toegestaan. Dat geldt in het bijzonder voor handelsmerken, model-benamingen, onderdeel nummers en tekeningen.*

*Τυχόν μη εξουσιοδοτημένη χρήση ή αντιγραφή των περιεχομένων οποιουδήποτε μέρους του παρόντος απαγορεύεται. Αυτό ισχύει ιδιαίτερα στα σήματα κατατεθέντα, τις ονομασίες μοντέλων, τους αριθμούς ανταλλακτικών και τα σχεδιαγράμματα.*

*Sisällön tai sen osan luvaton käyttö tai kopiointi on kielletty. Tämä koskee erityisesti tavaramerkkejä, mallien nimiä, osanumeroita ja piirustuksia.*

*Enhver ikke-autoriseret brug eller kopiering af indholdet eller nogen del deraf er forbudt. Dette gælder især varemærker, modelbetegnelser, reservedelsnumre og tegninger.*

*Enhver ikke godkjent bruk eller kopiering av innholdet eller noen del av det er forbudt. Dette gjelder i særlig grad varemerker, modellbetegnelser, delnummer og tegninger.*

*Ej i förväg godkänd användning eller kopiering av innehållet eller del av detta är förbjuden. Detta gäller speciellt varumärken, modellbeteckningar, reservdelsnummer och ritningar.*